

**PIACER**

Piattaforma  
Progettazione  
Gestione

Comunità  
Energetiche  
Rinnovabili

PIACER – Meeting di aggiornamento

Teams



**Attività svolta dal CIRI FRAME**

**14/07/2025**



### WP1 - Coordinamento e Gestione

- **LEAP**, CIDEA, CIRI FRAME, MECHLAV, ENEA CROSS-TEC

### WP2 – Specifiche piattaforma e tool

- **CIRI FRAME**, LEAP, CIDEA, MECHLAV, ENEA CROSS-TEC

### WP3 - Sviluppo tool

- **CIDEA**, CIRI FRAME, LEAP, MECHLAV, ENEA CROSS-TEC

### WP4 - Demo ed exploitation

- **MECHLAV**, CIDEA, CIRI FRAME, LEAP, ENEA CROSS-TEC

### WP5 – Diffusione

- **LEAP**, CIDEA, CIRI FRAME, MECHLAV, ENEA CROSS-TEC

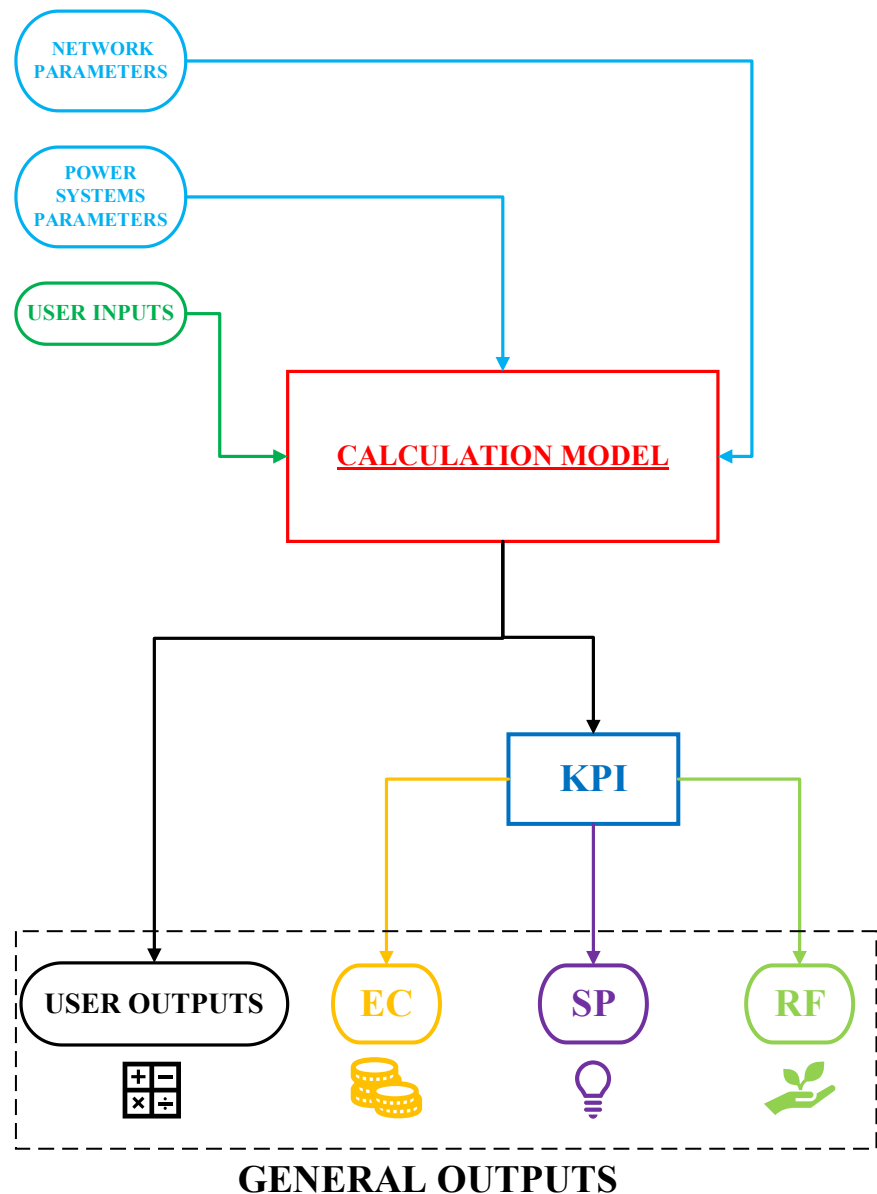

- ***Network parameters***: these are fixed conditions of the simulation, such as the number of users, the type of loads, the energy prices and the season in which the energy network's behavior is analyzed.
- ***Power system parameters***: this includes technical details about each user's power system, such as energy efficiency, the size of photovoltaic panels, or thermal solar plants.
- ***User inputs***: these are variable conditions that can be adjusted for each simulation. They include the energy production mix and the sizing of power systems for each user.
- ***Calculation model***: this model processes the inputs and parameters to compute the system's outputs.
- ***Key Performance Indicators (KPIs)***: this block analyzes the results from the calculation model to determine three key performance indicators: ***Extra Costs (EC)***, ***Self-Production (SP)***, ***Renewable Fraction (RF)***.
- ***User outputs***: these represent the results of the simulation for each user, divided into two categories: economic outputs (e.g., daily costs, CAPEX) and energy outputs (e.g., energy consumption, daily energy production).

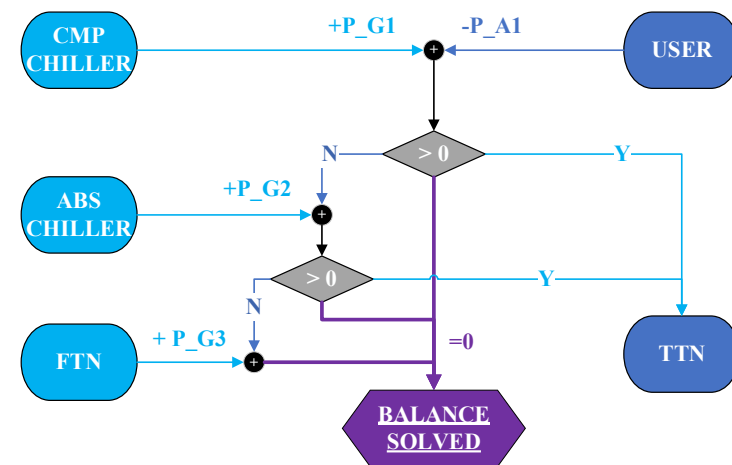
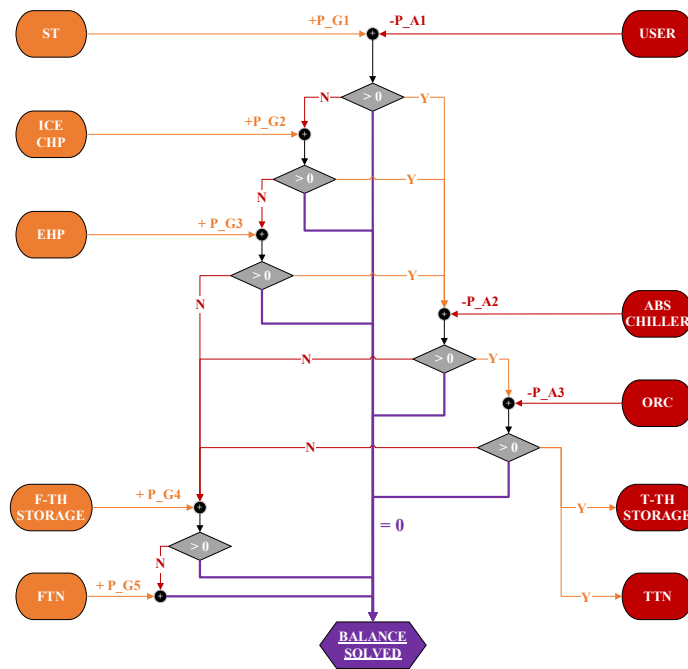
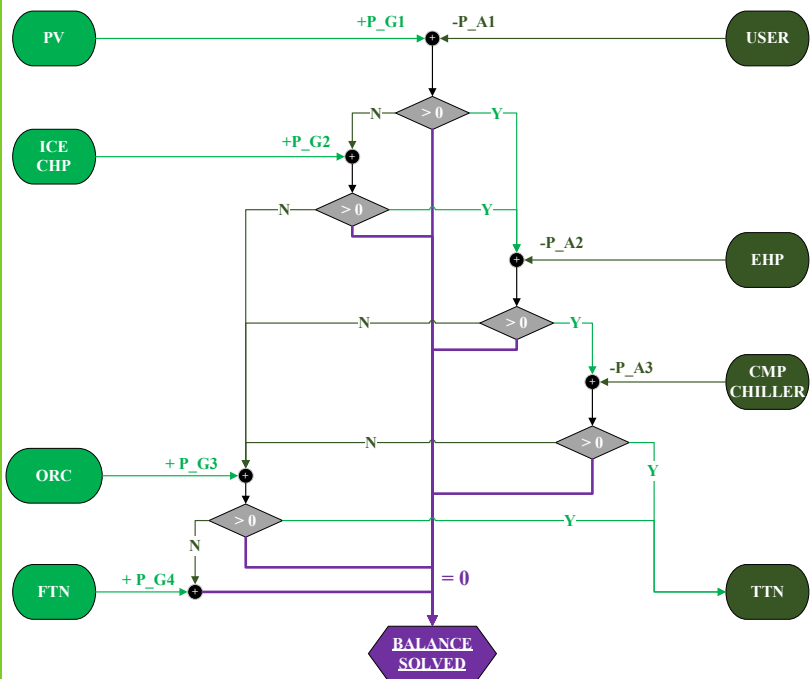

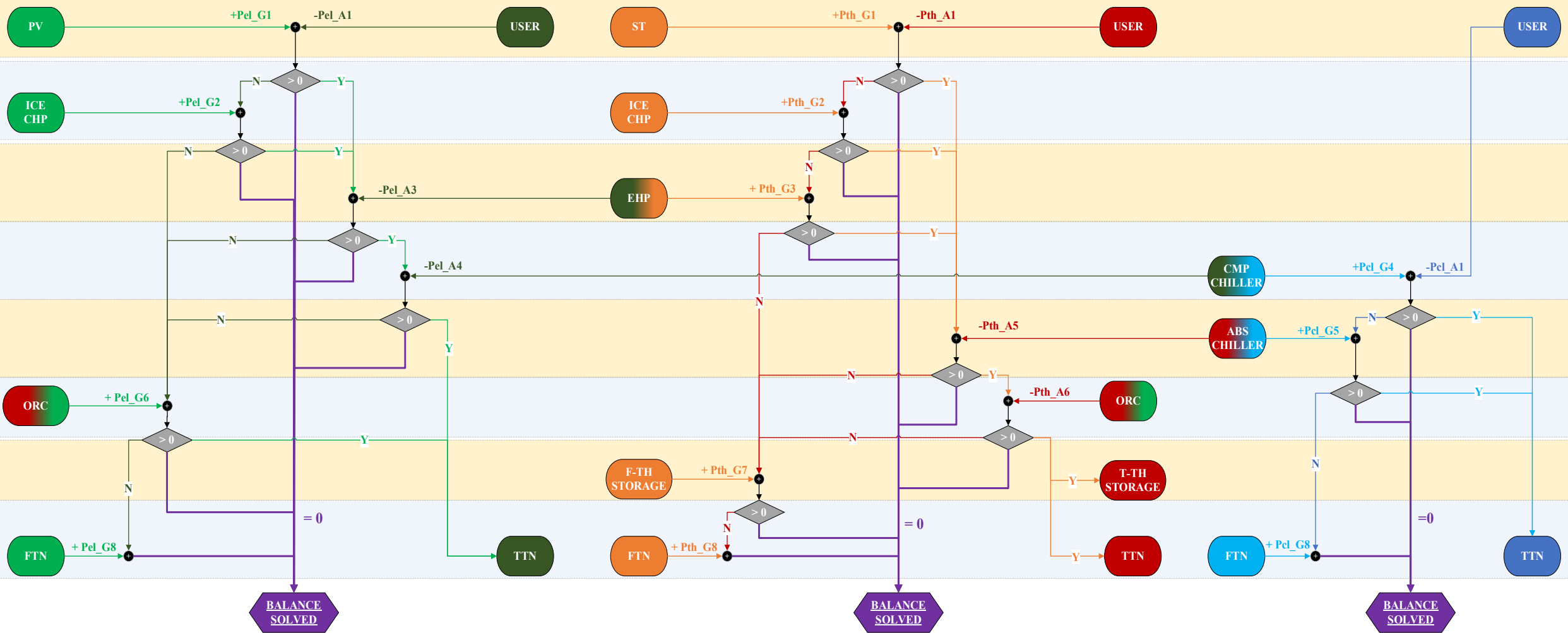

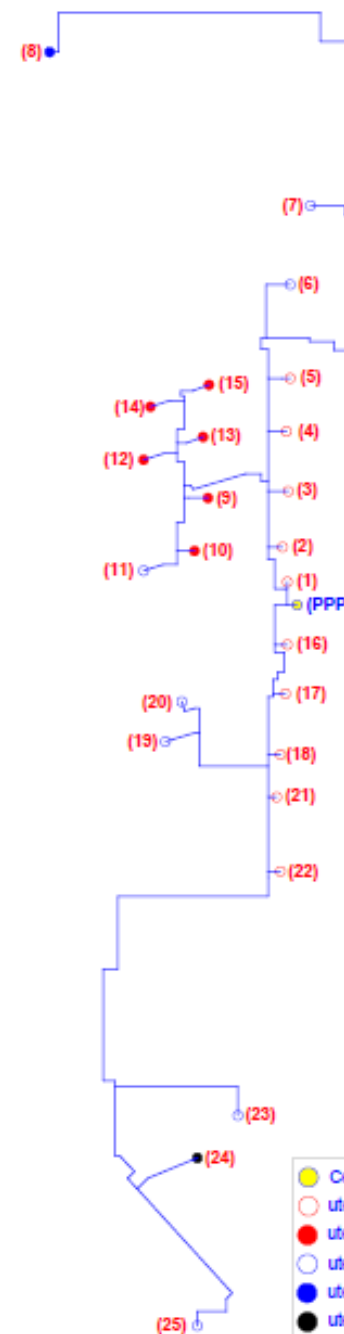

ID	Indirizzo
1	Via Giuseppe Tartini 44-46
2	Corso Taranto 104
3	Via Francesco Cilea 12-14
4	Corso Taranto 90
5	Via Saverio Mercadante 134-136
6	Corso Taranto 80
7	Corso Taranto 62-64-66
8	Via Monte Rosa 149
9	Via Pietro Mascagni 10
10	Via Giuseppe Tartini 39-41-43
11	Via Giuseppe Tartini 35
12	Via Francesco Cilea 1-3-5
13	Via Francesco Cilea 7-9-11
14	Via Gianbattista Pergolesi 55
15	Via Pietro Mascagni 2
16	Via Pietro Mascagni 21
17	Corso Taranto 122
18	Corso Taranto 130
19	Via Gianbattista Pergolesi 93
20	Via Gianbattista Pergolesi 91
21	Corso Taranto 136
22	Corso Taranto 146
23	Via Giovanale Ancina
24	Area Via Giovanni Cravero/Via Senigallia
25	Via Bologna 267

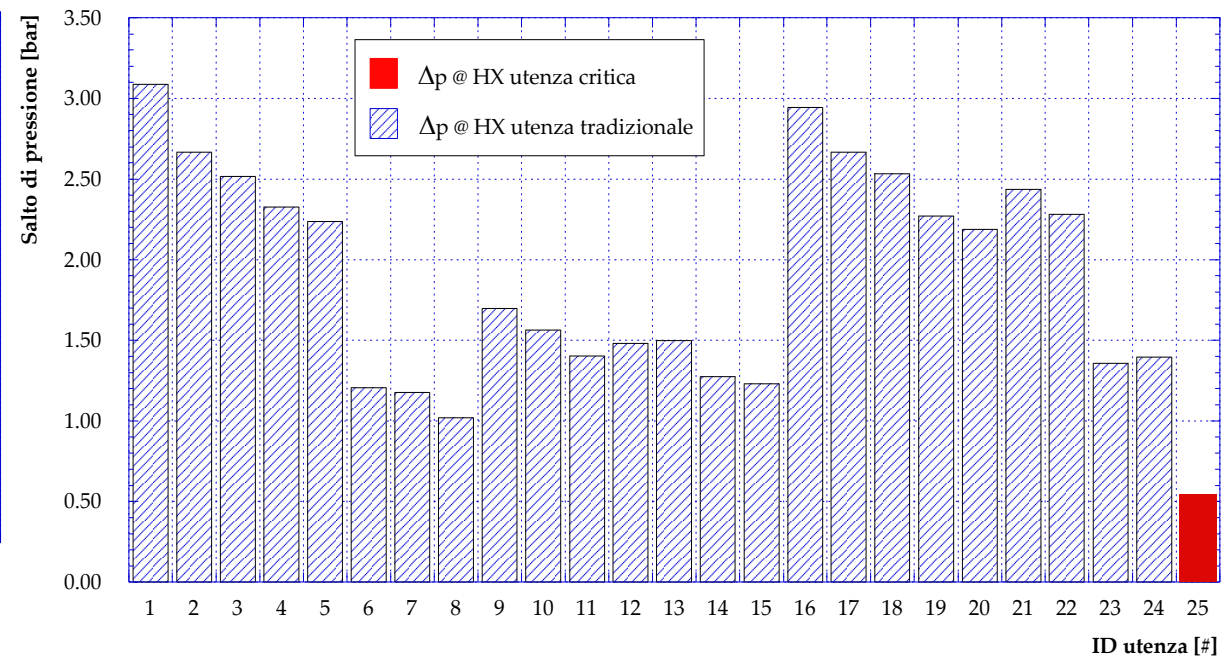
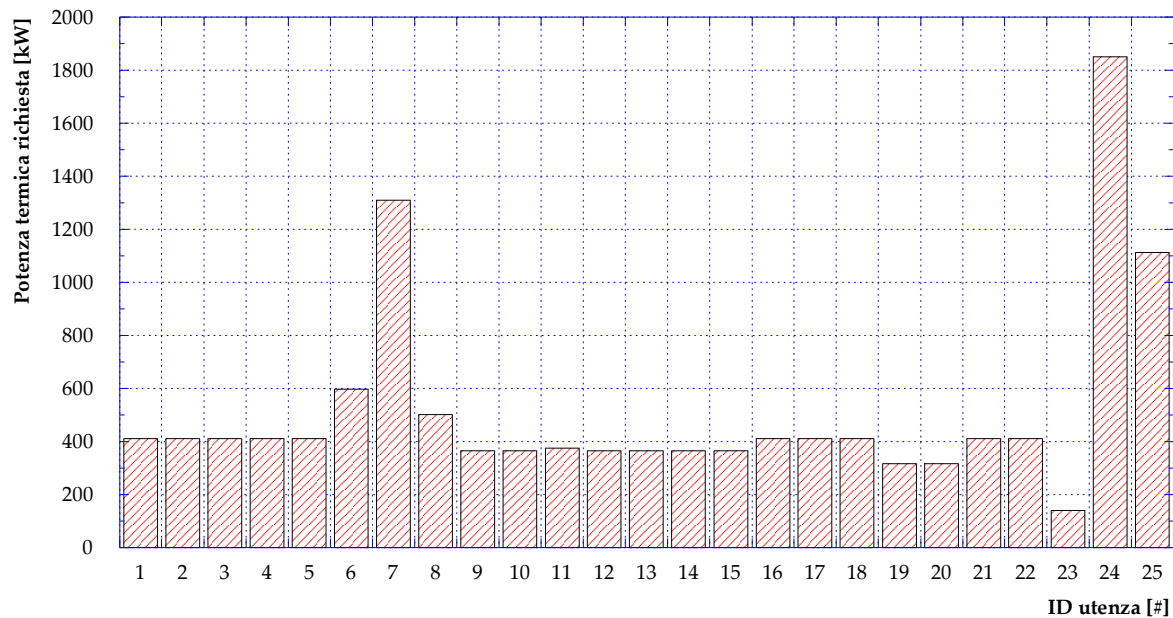

$\dot{m}_{DH,in}$	$Q_{TH,U}$	$Q_{TH,TPP}$	$P_{PMP,EL}$
196.7 [kg/s]	16474 [kW]	20016 [kW]	106 [kW]

ID utenza	1	2	3	4	5	6	7	8	9	10	11	12	13	14	15	16	17	18	19	20	21	22	23	24	25
ID IHENA	4	11	14	18	21	27	36	42	52	57	61	67	71	77	83	87	96	101	107	111	114	117	127	135	140
fabbisogno	RISC + ACS	RISC + ACS	RISC + ACS	RISC + ACS	RISC + ACS	RISC	RISC	RISC + ACS	RISC + ACS	RISC + ACS	RISC	RISC + ACS	RISC + ACS	RISC + ACS	RISC + ACS	RISC + ACS	RISC + ACS	RISC + ACS	RISC	RISC	RISC + ACS	RISC + ACS	RISC	RISC + ACS	RISC
tipo	1-a	1-a	1-a	1-a	1-a	2-a	2-a	2-b	1-b	1-b	2-a	1-b	1-b	1-b	1-b	1-a	1-a	1-a	2-a	2-a	1-a	1-a	2-a	3	2-a
Pel,R-UT,max [kW]	87	87	87	87	87	125	275	105	77	77	79	77	77	77	77	87	87	87	67	67	87	87	30	389	234
Pth,R-UT,max [kW]	412	412	412	412	412	597	1,310	502	366	366	375	366	366	366	366	412	412	412	317	317	412	412	141	1,851	1,113
Pfr,R-UT,max [kW]	206	206	206	206	206	299	655	251	183	183	188	183	183	183	183	206	206	206	159	159	206	206	71	926	557
Pfuel,R-UT,max [kW]	8	8	8	8	8	12	27	10	7	7	8	7	7	7	7	8	8	8	7	7	8	8	3	37	23
Pel,P-PV,max [kW]	0	0	0	0	0	0	0	0	0	0	0	0	0	0	0	0	0	0	0	0	0	0	0	0	0
Pth,P-ST,max [kW]	54	54	54	54	54	0	0	0	65	65	0	65	65	65	65	54	54	54	0	0	54	54	0	0	0
Pel,P-CG,max [kW]	0	0	0	0	0	0	0	0	0	0	0	0	0	0	0	0	0	0	0	0	0	0	0	0	0
Pth,P-CG,max [kW]	0	0	0	0	0	0	0	0	0	0	0	0	0	0	0	0	0	0	0	0	0	0	0	0	0
ETAel,CG,max [-]	0	0	0	0	0	0	0	0	0	0	0	0	0	0	0	0	0	0	0	0	0	0	0	0	0
EER-ASS,max [-]	0.67	0.67	0.67	0.67	0.67	0.67	0.67	0.67	0.67	0.67	0.67	0.67	0.67	0.67	0.67	0.67	0.67	0.67	0.67	0.67	0.67	0.67	0.67	0.67	0.67
EER-CMP,max [-]	4.00	4.00	4.00	4.00	4.00	4.00	4.00	4.00	4.00	4.00	4.00	4.00	4.00	4.00	4.00	4.00	4.00	4.00	4.00	4.00	4.00	4.00	4.00	4.00	4.00
COP-PdC,max [-]	5.00	5.00	5.00	5.00	5.00	5.00	5.00	5.00	5.00	5.00	5.00	5.00	5.00	5.00	5.00	5.00	5.00	5.00	5.00	5.00	5.00	5.00	5.00	5.00	5.00

- 3 giorni/tipo anno;
- fabbisogno
  - elettrico;
  - termico (riscaldamento + acs);
  - frigorifero;
  - gas naturale;
- profilo produzione
  - fotovoltaica;
  - solare termica.



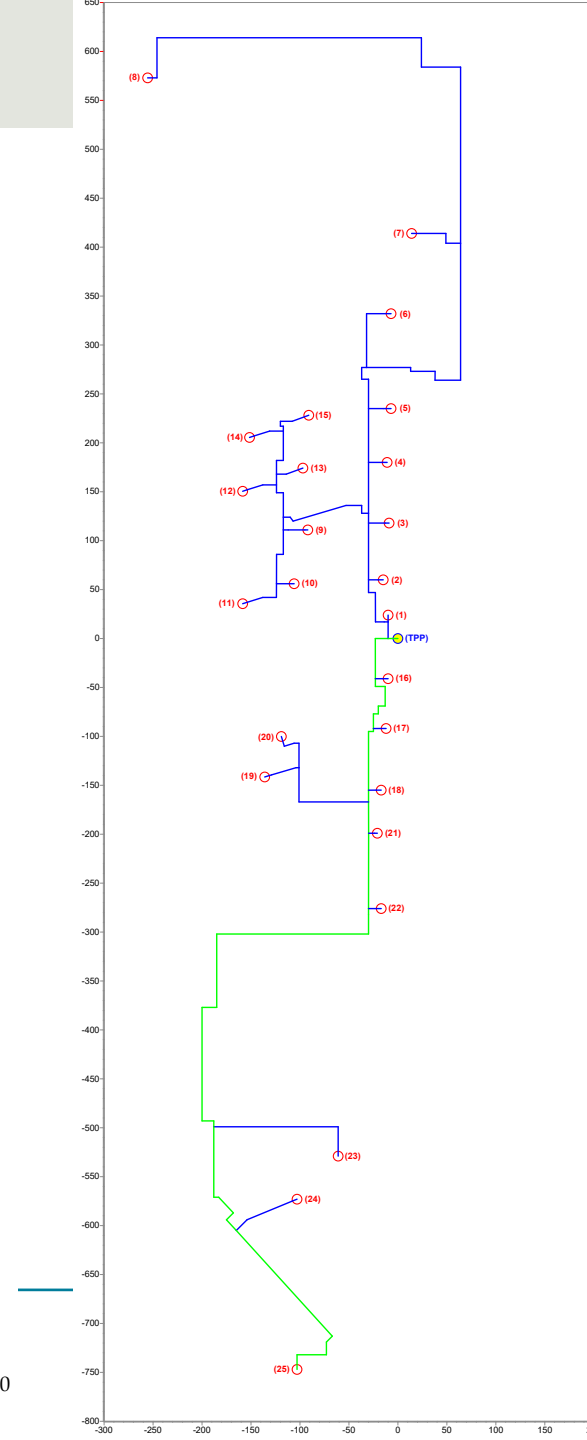
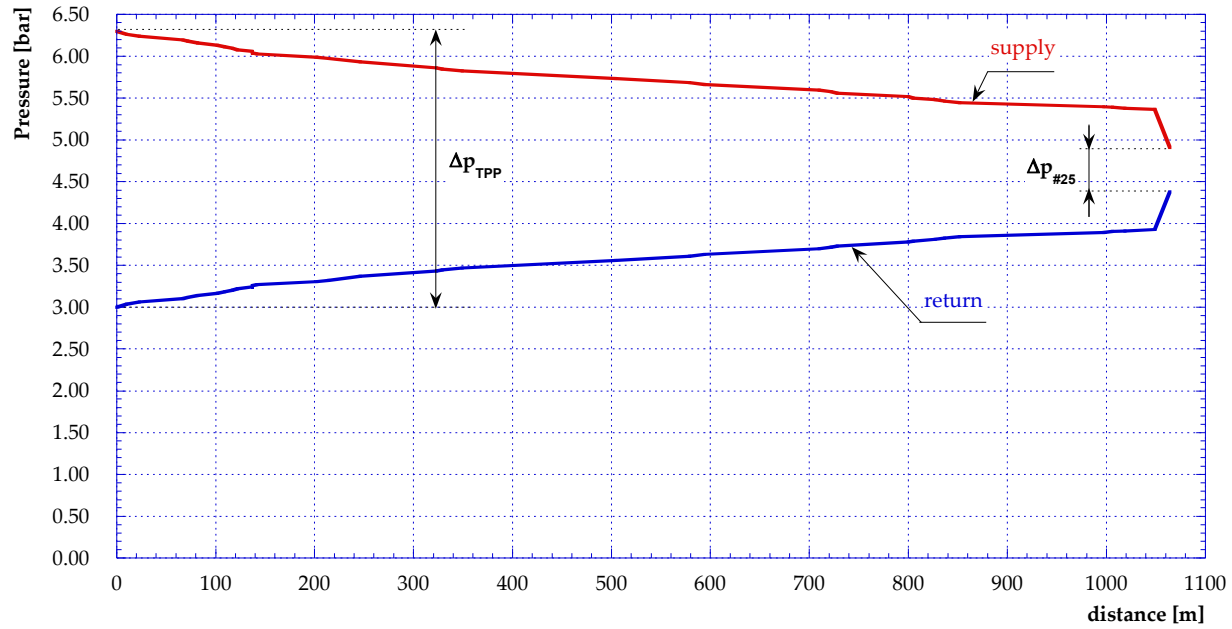
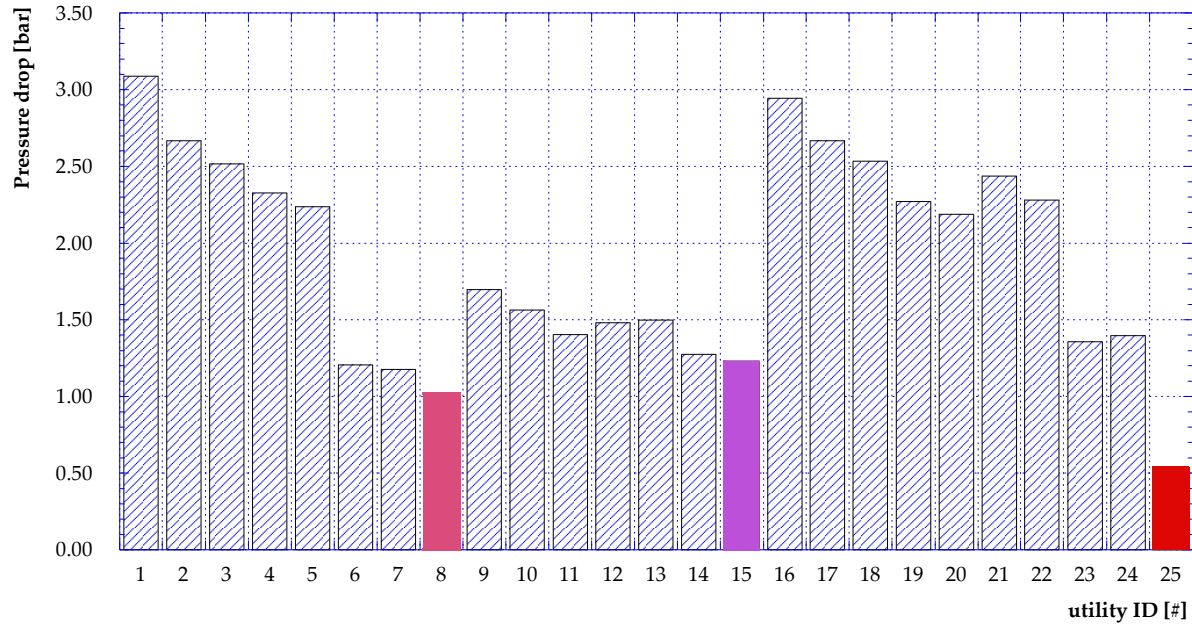

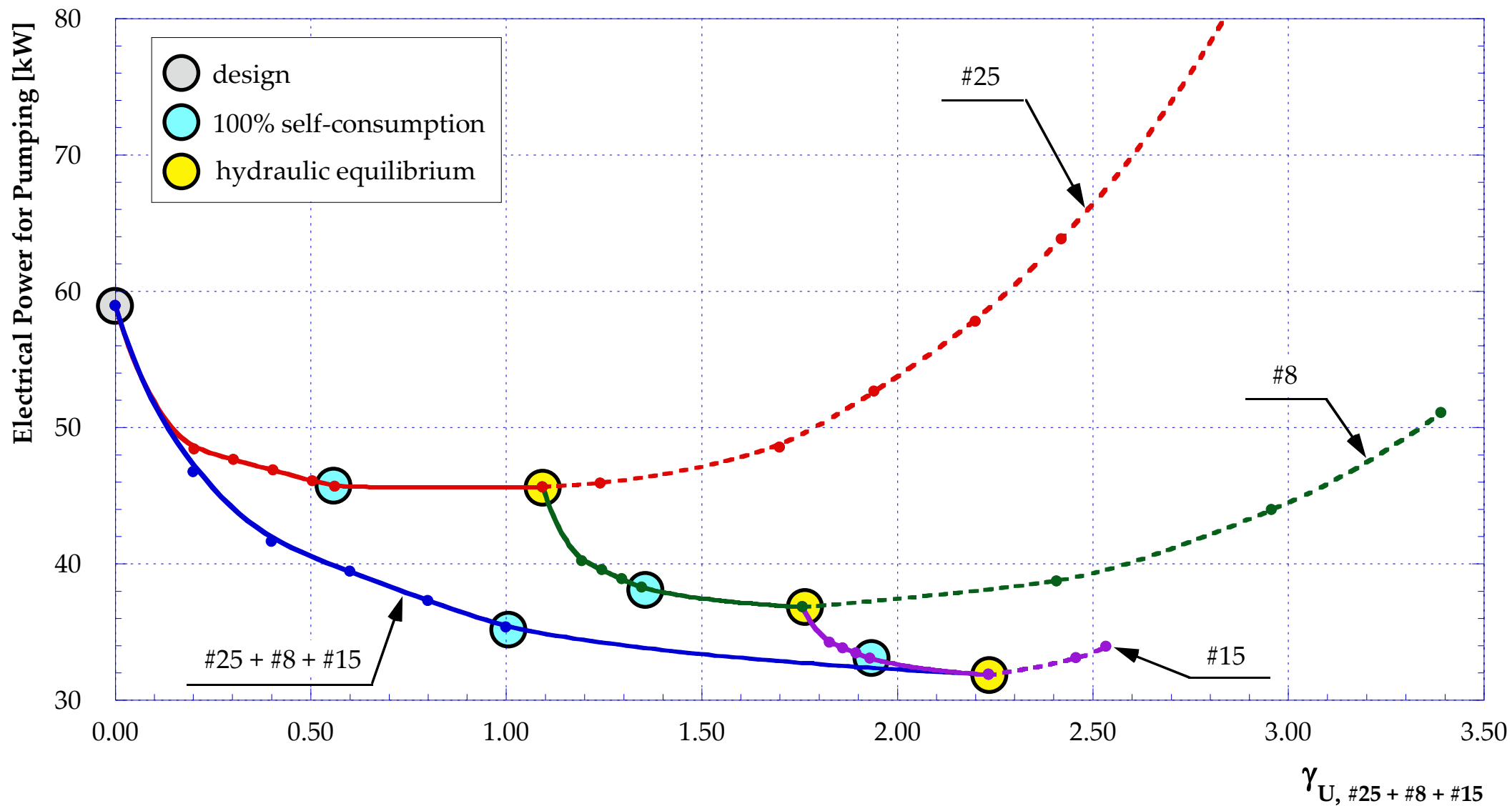

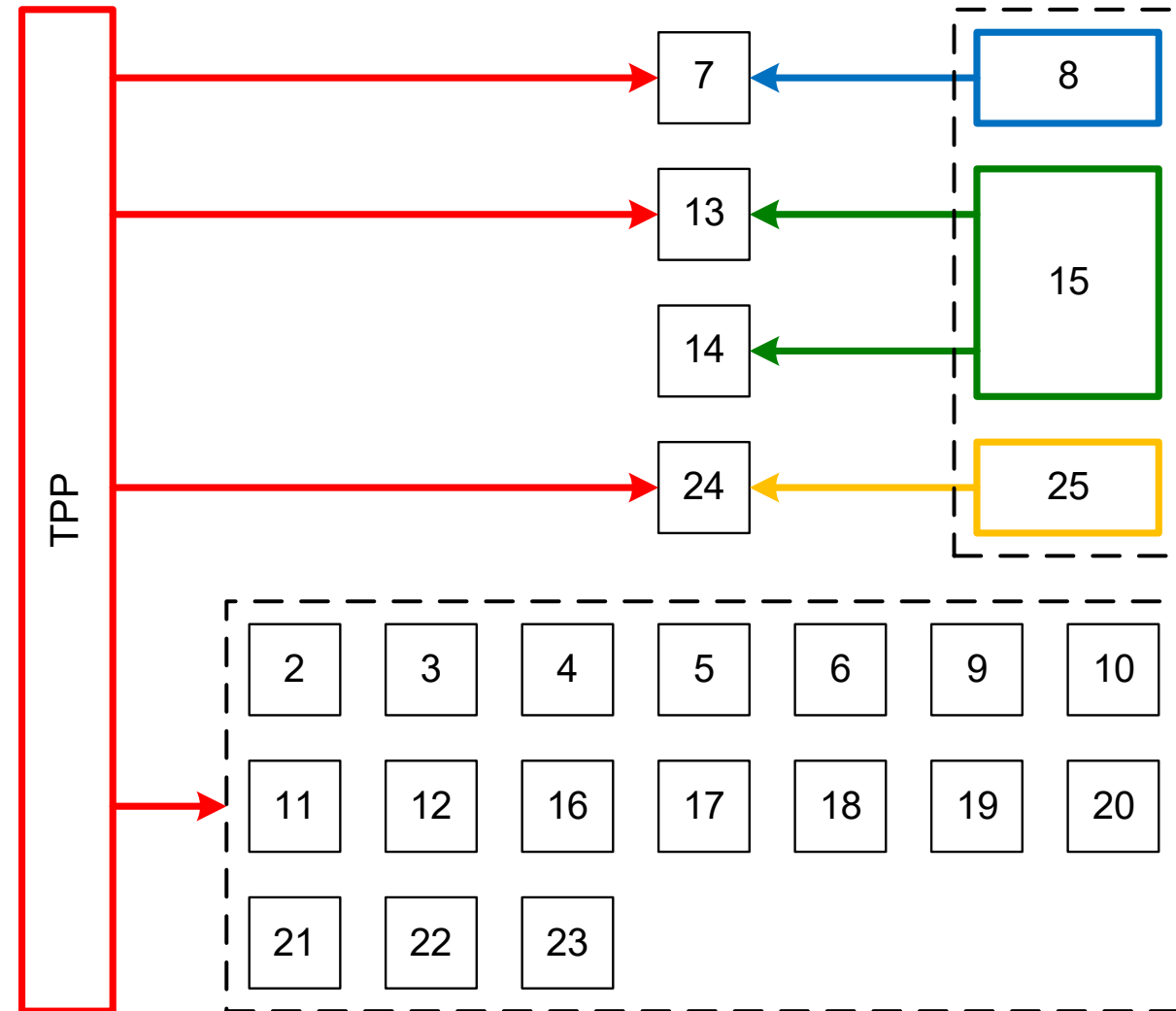
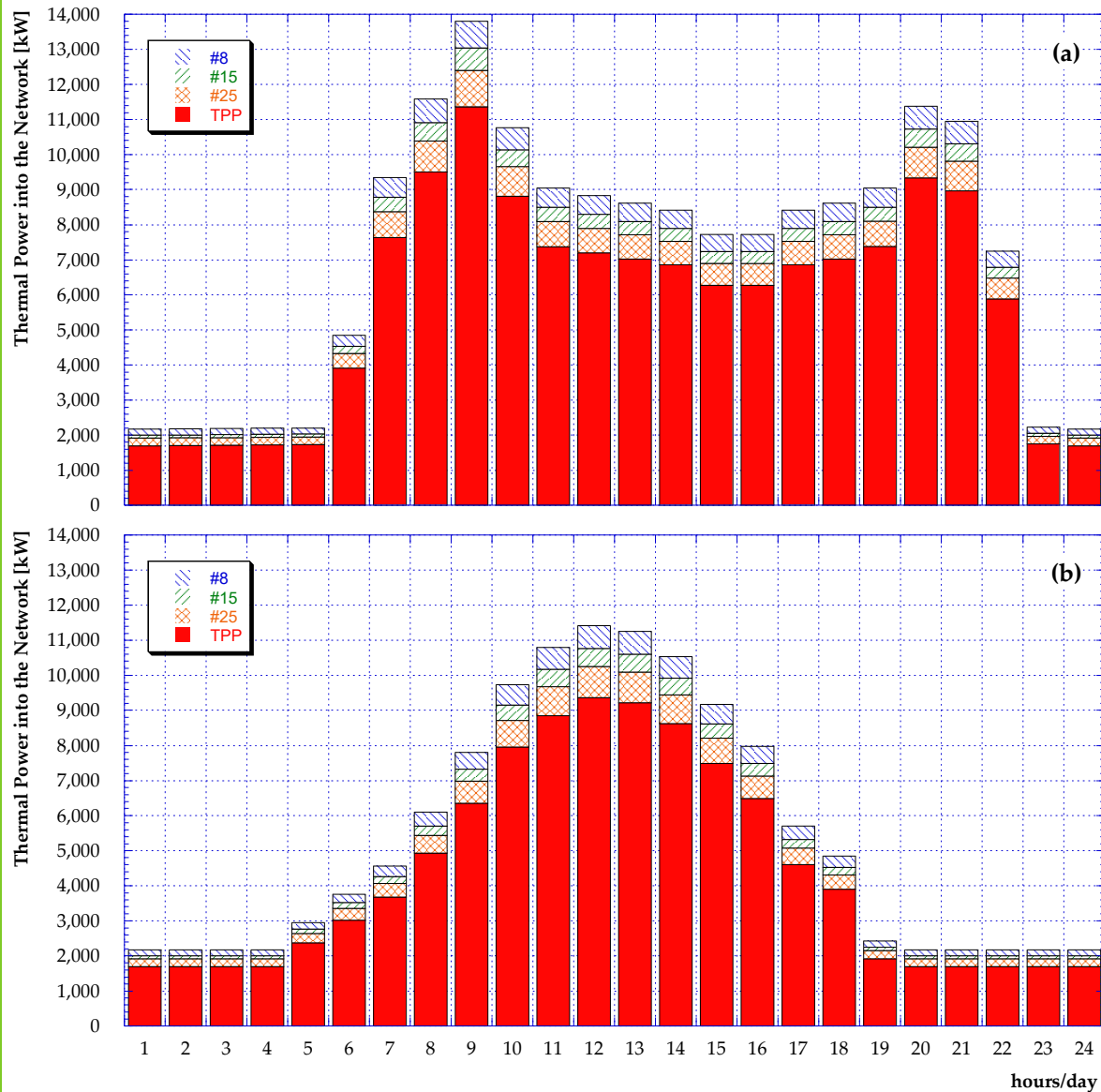

Introduced thermal power into the network by TPP and smart users for (a) typical winter day and (b) middle season and/or summer day

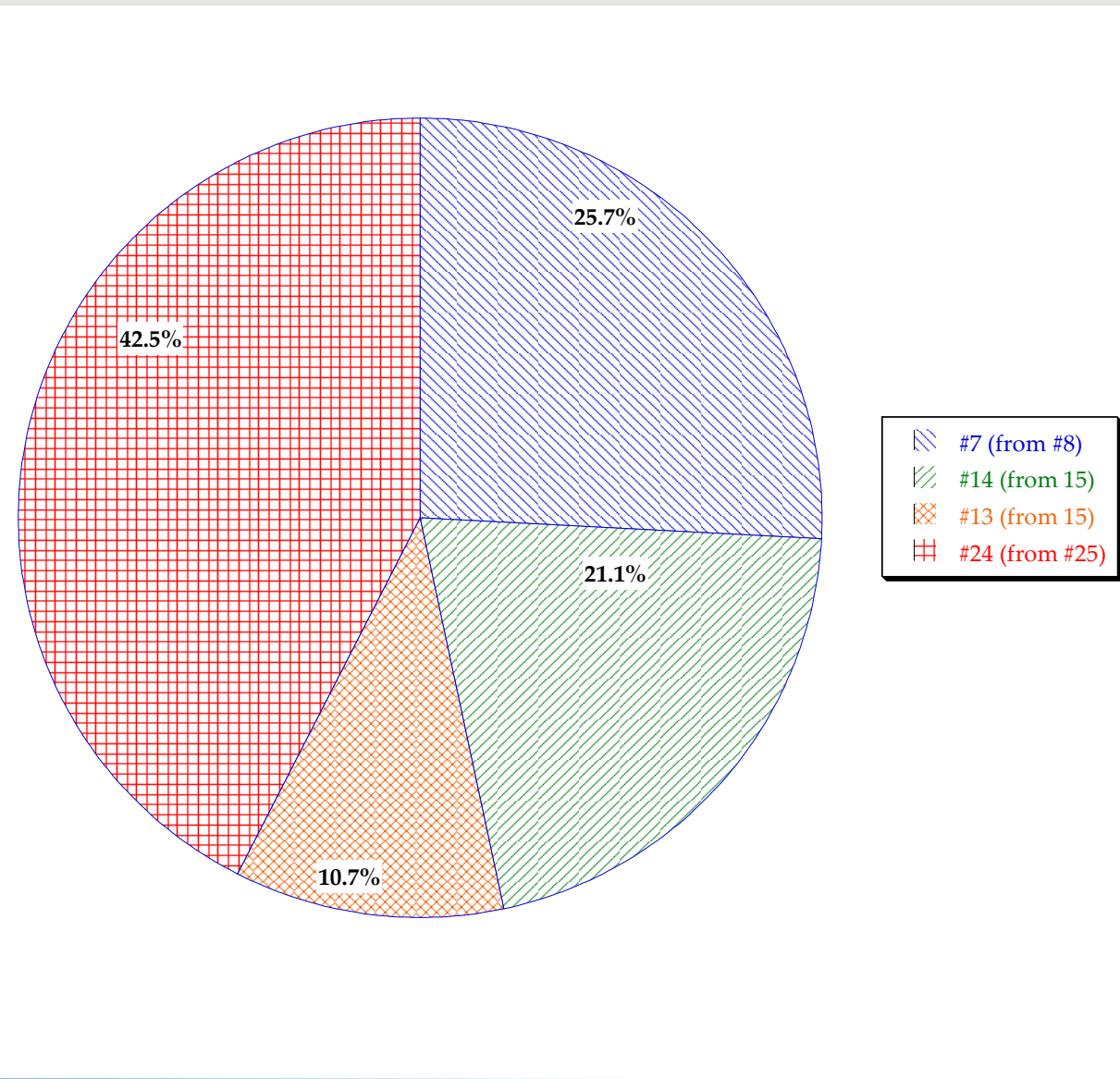
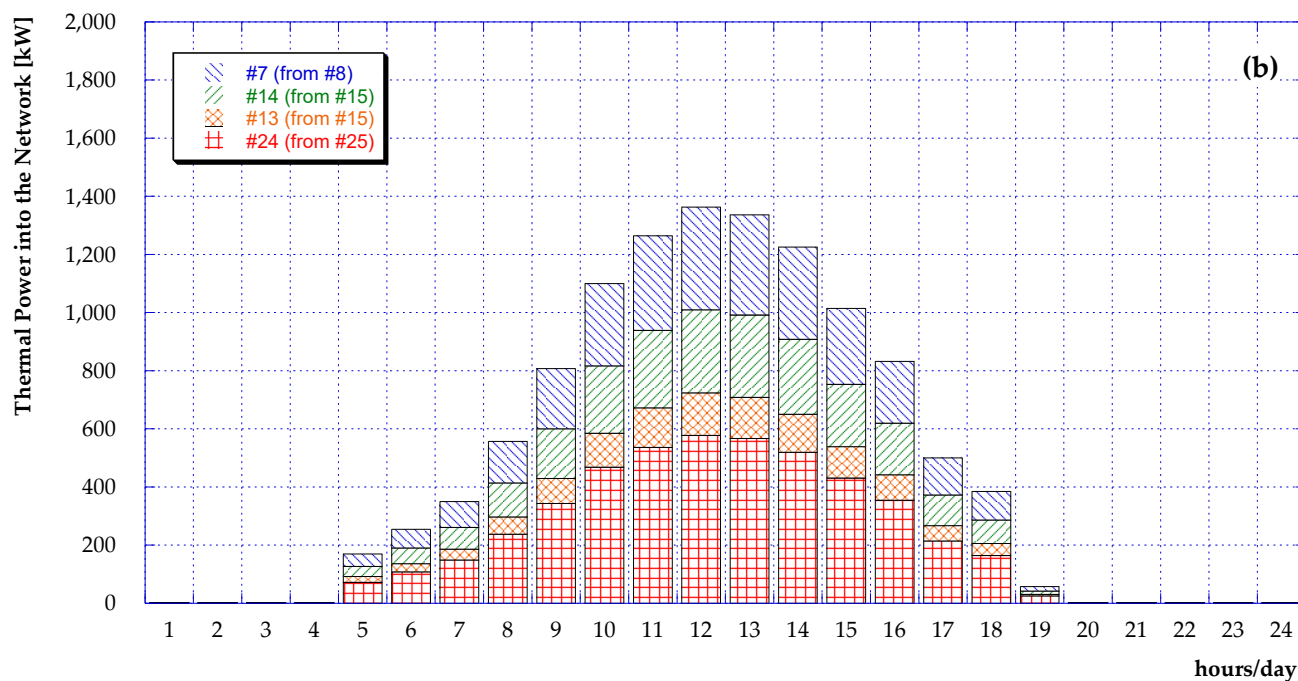
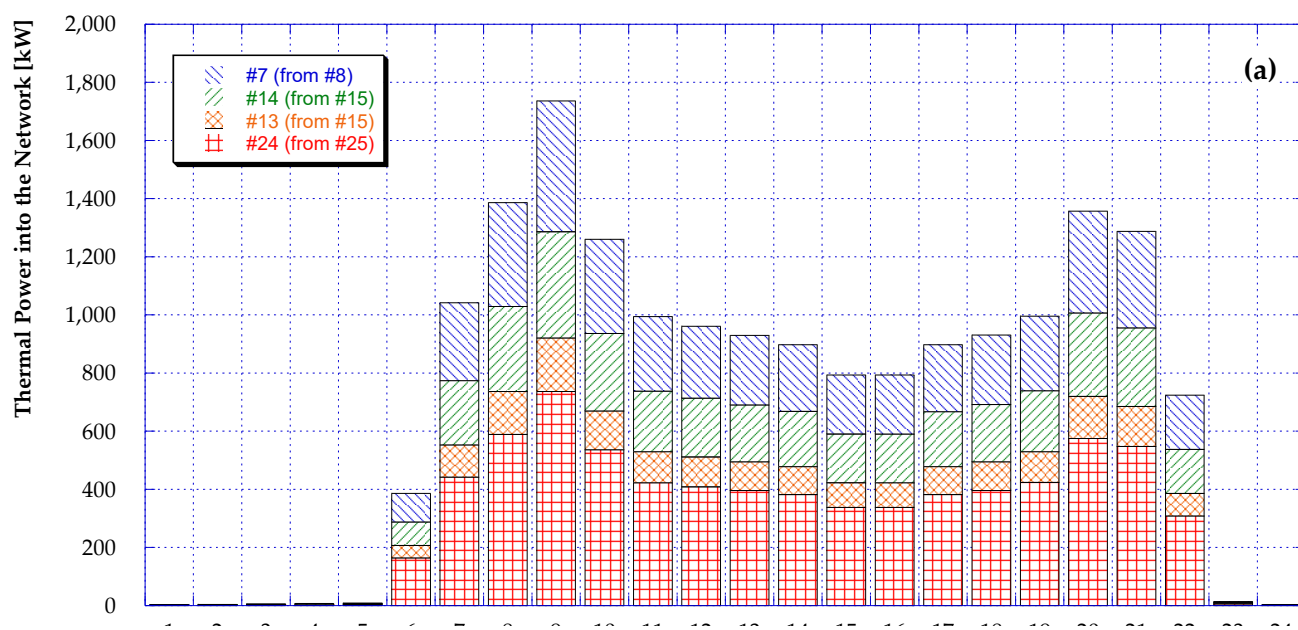

Shared thermal power: served users and sharing smart users for (a) typical winter day and (b) middle season and/or summer day

